

PRODUCTIONSYSTEMS

LP305D GATEWAY

- Powerful gateway for Binar's BPS system.
- Quick connections allow for effortless installation.
- Short circuit and overload protection provided.
- Diagnostic functions available for bus communication, voltage, and current.

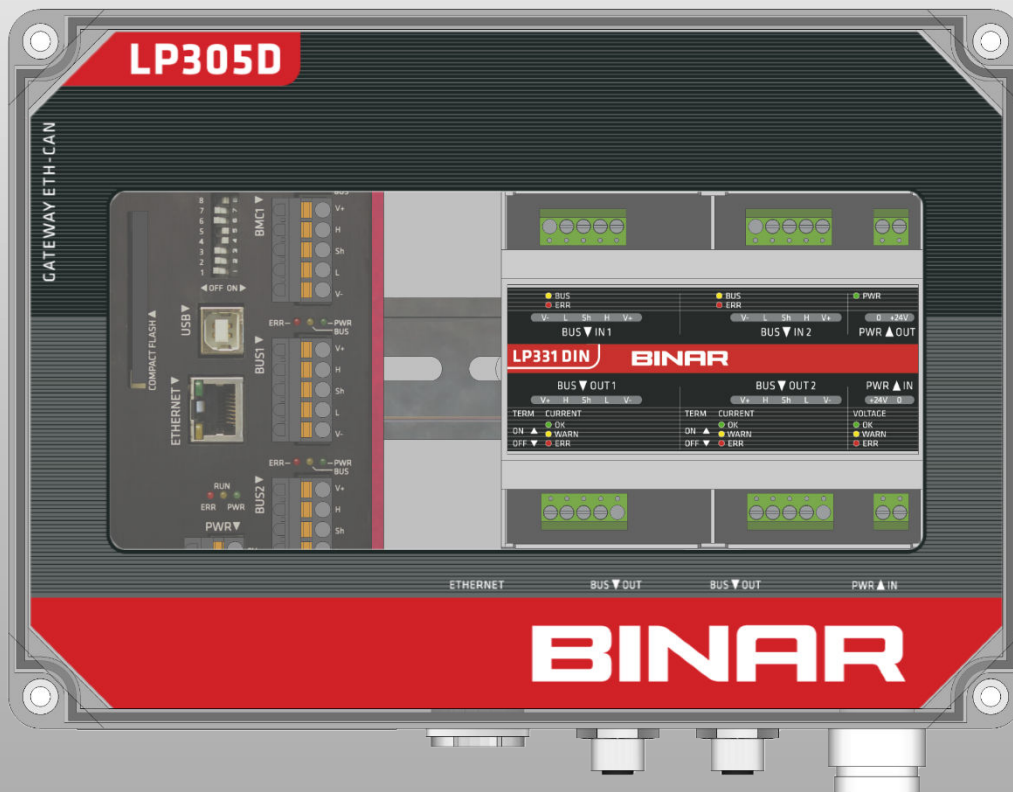

LP305D GATEWAY

The LP305D Gateway functions as a smart communication concentrator, efficiently managing logic and communication between the parent system and CAN nodes in Binar's BPS system.

The parent system is connected via Ethernet and an RJ45 connector, and the protocol used is VD (Virtual Device), which originated as a Volvo protocol developed for communicating between MES and equipment.

Voltage is supplied through the 7/8 connector. The recommended unit is LP-PW4 30VDC 4 Amp.

Voltage is distributed via each M12 connector into the two field buses. If the outlet current is greater than the supply source, LP331 voltage and diagnostic nodes can be connected. However, exceeding 70 nodes per bus loop can overload communication.

A-coding is utilized for M12 connections.

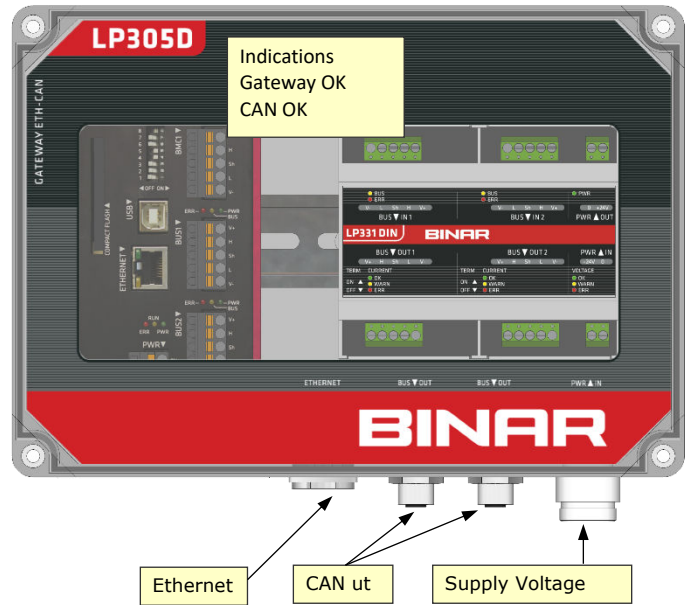

Status-LED

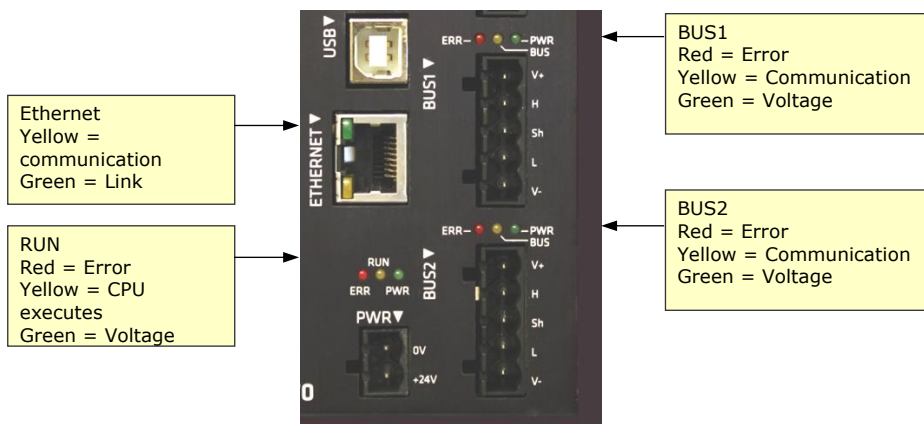

Outgoing 24V DC power to the CAN buses is equipped with automatic fuses PFCs, which will trip if the load exceeds 4 Amperes per M12 connector.

Detection of a new node on the CAN bus.

A node that is connected to the CAN bus reports its existence. The Gateway unit keeps track of the available nodes, and if any changes occur, this information is relayed to the higher-level system. In practice, this means that nodes begin communicating as soon as they are connected to the bus. You can tell that a node has power by observing the green PWR indicator, and that the Gateway has detected it and started communication through the yellow BUS indicator. To achieve the desired functionality with the nodes, the parent system must first send the configuration to the Gateway.

Changing the node on the CAN loop.

The Gateway compiles a list of detected nodes on the CAN bus. If a node is removed from the loop, it remains in memory for approximately 20 seconds before being removed. Only after that period, it is deleted. New nodes are automatically added if the maximum allowed number is not exceeded. All changes are reported to the parent system.

Changing the Gateway

The Gateway device includes only uniquely set network parameters. Therefore, if replacement is necessary, these parameters must be set on the new device as a minimum requirement to replace the old one. The network parameters are indicated on the underside of the Gateway unit. In addition, the Compact flash card contains system programs and any audio files loaded from the parent system.

The quickest and most secure method to alter the Gateway is by taking out the Compact flash card from the old device and inserting it into the new device.

1. Power down the gateway unit and disconnect all connections from underneath.
2. Remove the cover of the device.
3. Remove the compact flash card located on the left side of the BF70 unit.
4. Then, insert it into the new device and connect all cables and voltages.

Compact Flash

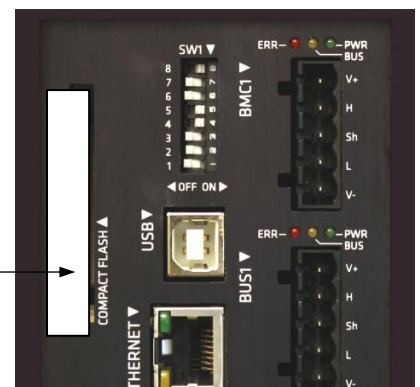

Binar Solutions AB

Box 2001 • SE-461 11 TROLLHÄTTAN • Sweden
tel +46 (0)520 47 32 00 • fax +46 (0)520 47 32 10
e-post info@binar.se • webb www.binarsolutions.se
2019-03-18 LP305DV1.00



BINAR
Improving your productivity

Voltage supply



The Gateway unit receives 30VDC through the 7/8 connector located on the underside. This voltage is then distributed to the CAN contacts and subsequently to subordinate CAN nodes. The combination of long CAN cables and high current consumption can lead to voltage drops. It is important to ensure that the minimum voltage required for the LP units to function properly is not exceeded. Therefore, it may be necessary to check the voltage at the end of each loop.

A CAN cable with AWG22 specifications has a resistance of 5.3ohm/100m. The current from all nodes is combined and reaches its maximum at the start of the loop. Hence, it is not advisable to use a long CAN cable up to the first node. If a 30-meter CAN cable with 2.5 Amperes current is used, there will be a voltage drop of 4 volts at the first node. If the voltage on the CAN bus falls below the minimum level, extra voltage needs to be injected into the bus to raise it to a higher level. It is important to note that T-connector art.

50249 is intended solely for this purpose.

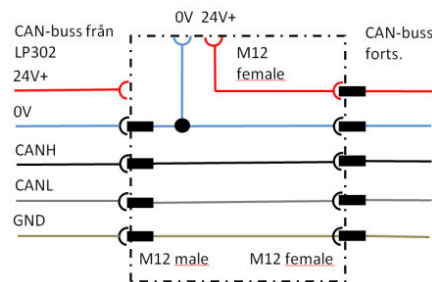

Current calculation

The maximum load for the Gateway unit is 4 Amperes per CAN bus loop continuously. The outgoing current is limited by a so-called PTC multi-fuse, which functions like a self-healing fuse. A green LED indicator shows whether there is voltage after the PTC on the output terminal in the unit. When the load has been reduced and remained low for some time, the PTC automatically resets. It is important to note that the maximum current of 4 Amperes also applies to the connectors for the CAN loop to avoid overloading them with additional power along the loop. Therefore, it is crucial to ensure that you do not exceed the maximum current when building your system. Here is an example of how the power consumption is calculated for a Gateway with subunits.

Unit	Power consumption /unit		Qty		Total Power consumption
LP305D - Gateway Eth/CAN	200 mA	x	1	=	200 mA
LP330 - Andon-nod	40 mA	x	6	=	240 mA
51338 - Andon-speaker on volume 5	160 mA	x	6	=	960 mA
50254 - Andon- white lit lamp	30 mA	x	1	=	30 mA
LP111 - Andon-button lit	10 mA	x	0	=	
LP315 - I/O-unit 4 in/out	40 mA	x	0	=	
LP215 - I/O-unit 4 in/out	70 mA	x	0	=	
LP216 - Bypass unit	110 mA	x	0	=	
LP113 - Pick indicator button lit	10 mA	x	0	=	
LP115 - Pick sensor off	24 mA	x	0	=	
LP115 - Pick sensor lit	40 mA	x	0	=	
			Total	=	1430 mA

Binar Solutions AB

Box 2001 • SE-461 11 TROLLHÄTTAN • Sweden
 tel +46 (0)520 47 32 00 • fax +46 (0)520 47 32 10
 e-post info@binar.se • webb www.binarsolutions.se
 2019-03-18 LP305DV1.00



BINAR
Improving your productivity

Max number of CAN nodes

The maximum number of CAN nodes per loop is approximately 70. To be able to connect that number, the power supply must be properly designed and distributed so that no nodes on the loop receive too low voltage.

The CAN bus and termination

The LP305D gateway communicates with its sub-units via the CAN bus (Controller Area Network). The bus speed is 125 kbit/s, and the maximum length of the CAN bus at this bus speed is 450 meters. The CAN bus is connected from node to node without branch connections in a so-called star network configuration. CAN cables designed for LP equipment must be used.



For the CAN bus to function properly, it must be equipped with a termination resistor at the end. This is done with the LP239 termination resistor, which is connected to the "CAN Out" connector on the last unit in the CAN loop. If you are using the picking indication board LP35x, there is a special termination resistor designed for the picking board that should be used.

LP239 CAN-termination



Unique MAC-addresses

Newer LP300 products use 29-bit extended CAN and unique MAC addresses, such as 81 00 66. These addresses are in hexadecimal form and cannot be altered. Utilizing unique addresses has several advantages, such as not requiring on-site setup and preventing double addressing issues, which can cause problems. The addresses serve to identify the device and link it to a specific physical location. The parent system establishes a connection to enable device communication. Each unit is labelled with the address in both plain text and dash format.

For LP21x units that are older, it is necessary to set up a CAN address. This can be done by using either rotary switches or a DIP switch, depending on the version, which are mounted on the circuit board of the devices. They are

accessible once unscrewed from the lid of the box. It's important to note that the unit's supply voltage should not be connected while changing the CAN address. Consult the separate documentation for configuring these devices.



Label on LP330 with MAC address 810066 (HEX)

Binar Solutions AB

Box 2001 • SE-461 11 TROLLHÄTTAN • Sweden
tel +46 (0)520 47 32 00 • fax +46 (0)520 47 32 10
e-post info@binar.se • webb www.binarsolutions.se
2019-03-18 LP305DV1.00



BINAR
Improving your productivity

Technical data

TECHNICAL DATA	
Article number	50305 LP305D Standard Variants: 50303 LP303D Project specific 51302 LP302D Volvo Car 53305 LP305D Scania CV 51303 LP303 Expired, 50303 replaces. 51305 LP305 Expired, 50305 replaces. 52305 LP305 Expired, 53305 replaces.
IP-address	192.168.1.88 (Default)
Gateway	0.0.0.0 (Default)
Netmask	255.255.255.0 (Default)
Supply voltage	20 - 30 VDC
Power consumption	200 mA + power for CAN-nodes. Max power 2x4 Amp
Connector supply	3-pin 7/8-contact plug
Connector CAN	M12
Connector Ethernet	RJ45
CE	EN 61000-6-4 and EN 61000-6-2
Temperature area	0 – 45 °C
Protection Class	IP54
Weight	2.3 kg
Mounting	Screw Mounting
Dimensions	b254 x h197 x d164

CONNECTIONS

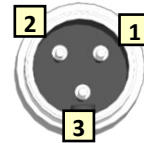

Supply voltage

3-pol 7/8-kontakt Stift

Pin	Signal	Cabel colour
1	+24V	Brown
2	0V	Blue
3	Earth	Green/yellow

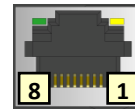

Ethernet

8/8 Modular connector

Pin	Signal
1	Transmit +
2	Transmit -
3	Receive +
6	Receive - (4,5,7,8 nc)



CAN UT 1&2

5-pole M12 connector

Pin	Signal
1	0V
2	+24V
3	0V
4	CAN High
5	CAN Low

Dimensions in cm

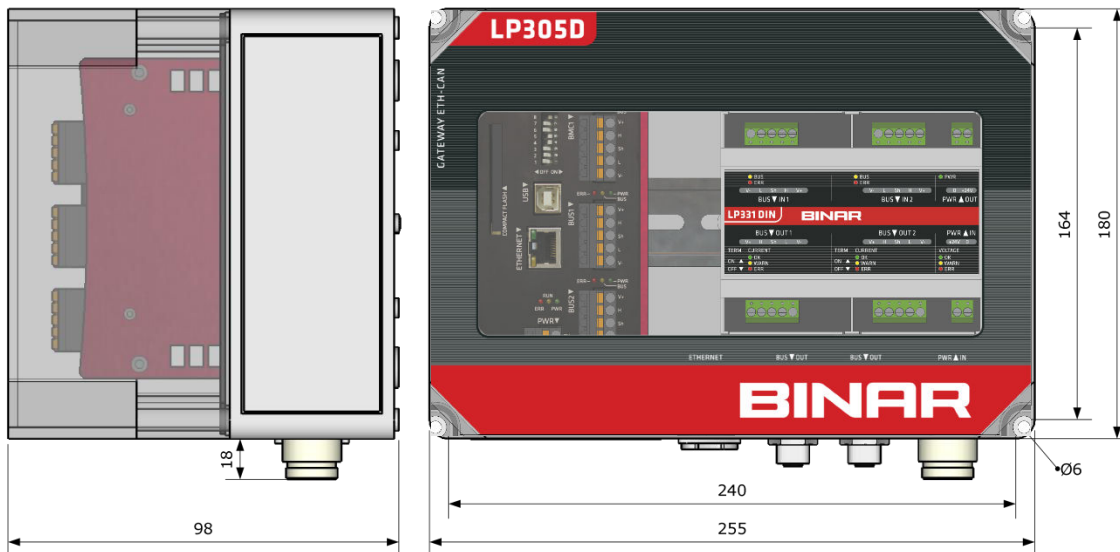

Binar Solutions AB

Box 2001 • SE-461 11 TROLLHÄTTAN • Sweden
tel +46 (0)520 47 32 00 • fax +46 (0)520 47 32 10
e-post info@binar.se • webb www.binarsolutions.se
2019-03-18 LP305DV1.00



BINAR
Improving your productivity