

BINAR CONTROL SYSTEMS

LP317 I/O-BOX

- I/O interface that exchanges digital signals and handles telegram exchange in Binar's quality assurance system.
- Quick connectors allow for easy installation
- Short circuit and overload protection
- Software controlled I/O configuration: 1 IN/1 OUT per M12, alternatively 2 IN



LP317 I/O-BOX

The **LP317** is an I/O box used for exchanging digital signals in production controls by Binar. It functions as a node in the network and communicates through the Controller Area Network (CAN), receiving its voltage via the same. It functions as a node in the network and communicates through the Controller Area Network (CAN), receiving its voltage via the same. The device comes with a serial port RS232 for handling telegram exchange, and all connectors are of the M12 type, making them easy to install and alter on the network. The I/O node is typically utilized in high-end systems like ELIN (Electronic Information) with pick indication and LPS (Lean Production Software). Its I/O interface is outfitted with four digital inputs and four digital outputs.

ADDRESSING

OPT. 1

The **LP317** unit features two address knobs at the bottom, which allow for the setting of CAN-ID 1 through 61. This configuration ensures backwards compatibility and serves as a replacement **LP215**.



OPT. 2

The device features a one-of-a-kind MAC address that eliminates the necessity of manually configuring an ID address. MAC addressing permits an unrestricted number of devices in the system while preventing address conflicts. By configuring the address knob to CAN-ID 0, the device automatically obtains its unique MAC address via a barcode and hexadecimal number located on the top label.



To use the new MAC address, you need the LP301 gateway and support in the superior system that reads the CAN loops during startup and manages configuration.

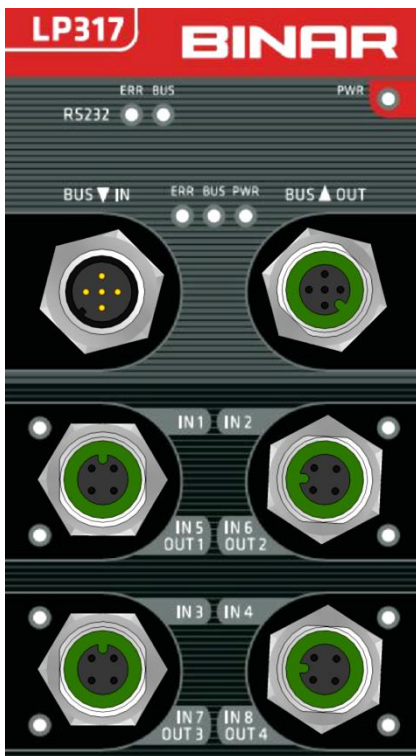

STATUSLAMPS

The green light on the Device PWR indicates that the device is receiving voltage.

RS232

Status on the RS232 serial channel is indicated through ERR and BUS signals, as presented in the table below.

CAN

The CAN bus status is displayed via ETT, BUS, and PWR as shown in the table below.

I/O

The LEDs on the outer edge indicate the active signal with a yellow light.

STATUSINDICATIONS

RS232

PWR = Voltage out 24VDC OK
 BUS = CAN-bus comm. OK
 ERR = Error on the CAN-bus.

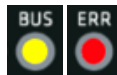

CAN-BUS

PWR = Voltage out 24VDC OK
 BUS = CAN-bus comm. OK
 ERR = Error on the CAN-bus.

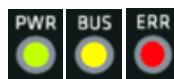

CONNECTIONS

CAN IN

5-pol M12-contact pin

Pin	Signal
1	0V
2	+24V
3	0V
4	CAN High
5	CAN Low



CAN UT

5-pol M12-contact sleeve

Pin	Signal
1	0V
2	+24V
3	0V
4	CAN High
5	CAN Low



I/O

4-pol M12-contact sleeve

Pin	Signal
1	+24V
2	OUT 1/IN 5
3	0V
4	IN 1



RS232

9-pol DSub pin

Pin	Signal
1	DCD
2	Rx
3	Tx
4	DTR
5	GND
6	DSR
7	RTS
8	CTS
9	RI



TECHNICAL DATA

Article number	50317
Supply voltage	20-32VDC
Power consumption	40mA
Connector	M12, A-coding CAN 5-pin, I/O 4-pin
Data transfer	CAN, 125 kbit/s
CE	EN 61000-6-4 and EN 61000-6-2
Temperature area	0 – 50 °C
Protection	IP51
Weight	430 g
Mounting	Screw mounting
Dimensions	b70 x d35 x h180
Digital inputs	4 - 8 pc PNP
Impedance inputs	4,5 kOhm
Filter inputs	Hardware filter 1ms, softwarefiles 5 ms
Digital outputs	0 - 4 pc, PNP, kortslutningsskyddade, termisk avstängning
Max current output	Per channel 1,9A, Total max 3,7A

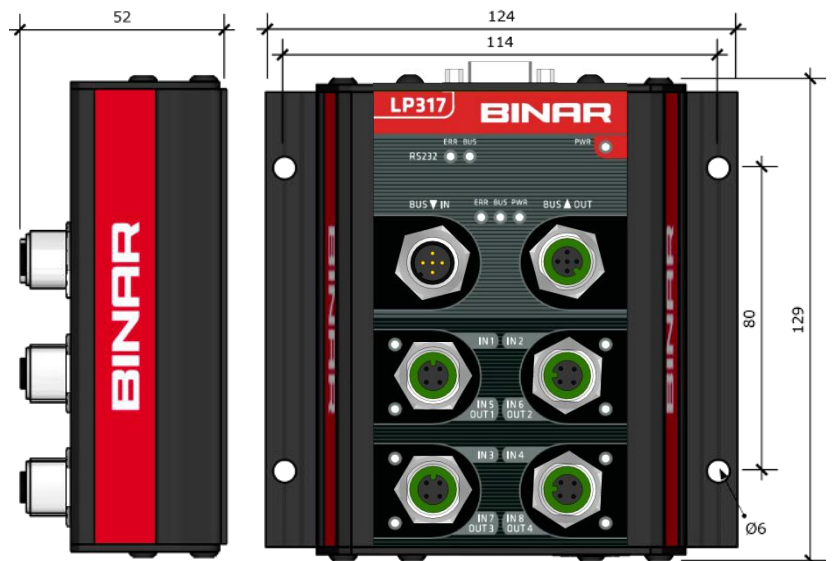

The device works with CAN nodes in the **LP3X** family and connects to a Gateway in the same product family through the CAN-in input. CAN, or Controller Area Network, is a bus that allows units in systems to communicate with each other quickly and securely. If multiple devices need to be connected in the system, the device uses CAN-out to forward the data flow. A termination resistor, **LP239**, must be connected to the CAN-out of the first and last unit in the system for the CAN bus to function properly.

SE ÄVEN



LP315 art. 50315.

Digital signal exchange in production controls facilitated through I/O box.

INSTRUCTION TO REPLACE LP215

LP217

LP317

CONNECTIONS

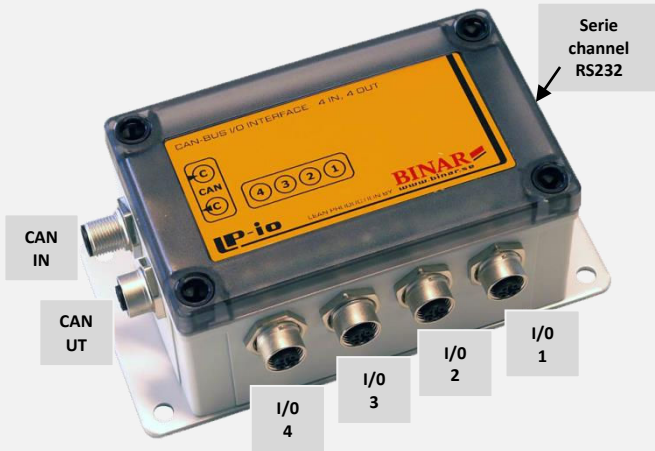

ADDRESSING

To access the addressing knob within the product, unscrew the top of the device. To access the addressing knob within the product, unscrew the top of the device. To access the addressing knob within the product, unscrew the top of the device. This will make the device's address visible.

The product's address knob is located on the bottom.



HOLE PICTURE

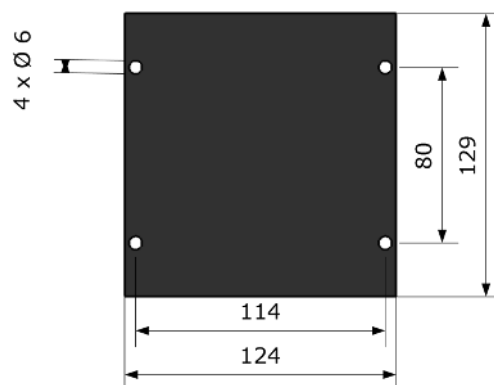
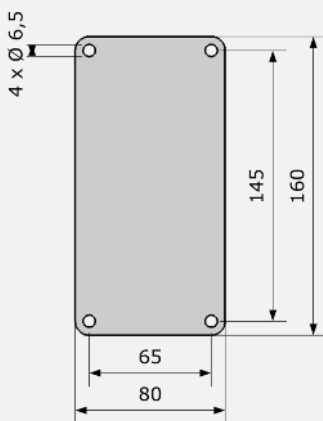

Binar Solutions AB

Box 2001 • SE-461 11 TROLLHÄTTAN • Sweden
 tel +46 (0)520 47 32 00 • fax +46 (0)520 47 32 10
 e-post info@binar.se • Webb www.binarsolutions.com



BINAR
 Improving your productivity