

BINAR CONTROL SYSTEMS

LP315 I/O-BOX

- I/O interface that exchanges digital signals in Binar's quality assurance system.
- Quick connectors allow for easy installation
- Short circuit and overload protection
- Software controlled I/O configuration: 1 IN/1 OUT per M12, alternatively 2 IN



Replaces I/O-box LP215

BINAR
Improving your productivity

LP315 I/O-BOX

LP315 is an I/O device made by Binar for exchanging digital signals in production control systems. It acts as a node within a network and communicates via CAN (Controller Area Network). The device is supplied power through the CAN bus, and all connections are of the M12 type, allowing for easy installation and network modifications. Typically, the I/O node is utilized in advanced systems like ELIN (Electronic Information) featuring pick indication and LPS (Lean Production Software). The I/O interface boasts 4 digital inputs and 4 digital outputs for optimal functionality.

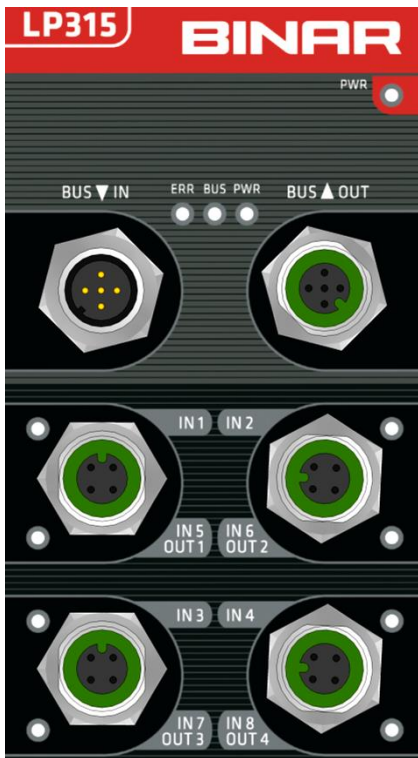

STATUSLAMP

The green light on the Device PWR indicates that the device is receiving voltage.

CAN

The CAN bus status is displayed via ETT, BUS, and PWR as shown in the table below.

I/O

The LEDs on the outer edge indicate the active signal with a yellow light.

ADDRESSING

OPT. 1

The 50315 features two address knobs located at the bottom, which allow for CAN-ID settings from 1 to 61. This configuration ensures backward compatibility and serves as a replacement for LP215.



OPT. 2

The device features a one-of-a-kind MAC address that eliminates the necessity of manually configuring an ID address. MAC addressing permits an unrestricted number of devices in the system while preventing address conflicts. By configuring the address knob to CAN-ID 0, the device automatically obtains its unique MAC address via a barcode and hexadecimal number located on the top label.



To utilize the new MAC address, it is necessary to have both gateway LP301 and support in the superior system that reads the CAN loops at startup and manages the configuration.

STATUSINDICATION

CAN-BUS

PWR = VOLTAGE 24VDC OK
 BUS = CAN-bus comm. OK
 ERR = Error on the CAN-bus



CONNECTIONS



CAN IN

5-pol M12- contact pin

Pin	Signal
1	0V
2	+24V
3	0V
4	CAN High
5	CAN Low



CAN UT

5-pol M12-contact sleeve

Pin	Signal
1	0V
2	+24V
3	0V
4	CAN High
5	CAN Low

I/O

4-pol M12-contact sleeve

Pin	Signal
1	+24V
2	OUT 1/IN 5
3	0V
4	IN 1



TECHNICAL DATA

Article number	50315
Supply voltage	20-32VDC
Power consumption	40mA
Connector	M12, A-coding CAN 5-pin, I/O 4-pin
Data transfer	CAN, 125 kbit/s
CE	EN 61000-6-4 and EN 61000-6-2
Temperature area	0 – 50 °C
Protection	IP51
Weight	430 g
Mounting	Screw mounting
Dimensions	b70 x d35 x h180
Digital inputs	4 - 8 pc PNP
Impedance input	4,5 kOhm
Filter inputs	Hardware filter 1ms, software files 5 ms
Digital outputs	0 - 4 pc, PNP, kortslutningsskyddade, termisk avstängning
Max current outputs	Per channel 1,9A, Total max 3,7A

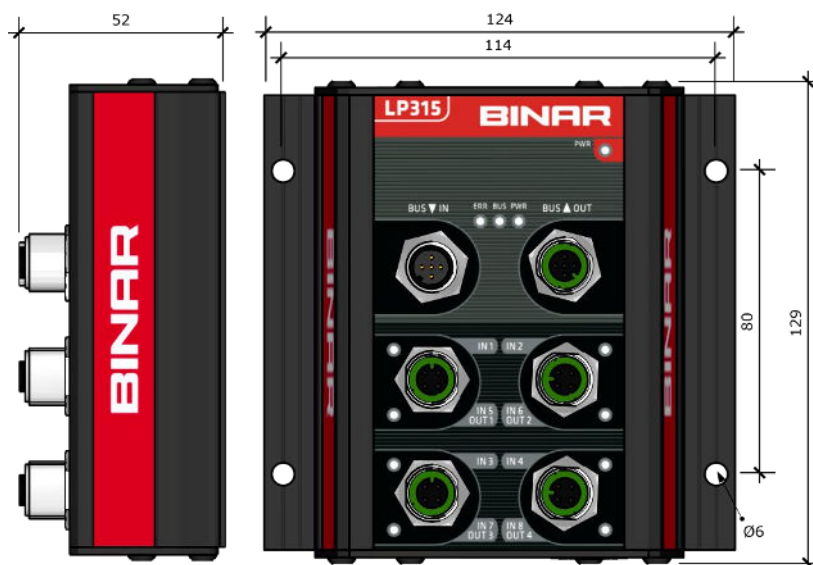

The device works with CAN nodes in the **LP3X** family and connects to a Gateway in the same product family through the CAN-in input. CAN, or Controller Area Network, is a bus that allows units in systems to communicate with each other quickly and securely. If multiple devices need to be connected in the system, the device uses CAN-out to forward the data flow. A termination resistor, **LP239**, must be connected to the CAN-out of the first and last unit in the system for the CAN bus to function properly.

SEE ALSO



LP317 art. 50317.
I/O box equipped with a serial port RS232 for exchanging digital signals in production controls and managing telegram exchange.

INSTRUCTION TO REPLACE LP215

LP215

LP315

CONNECTIONS



ADDRESSING

To access the addressing knob within the product, unscrew the top of the device. To access the addressing knob within the product, unscrew the top of the device. To access the addressing knob within the product, unscrew the top of the device. This will make the device's addressing visible.

The product's address knob is located on the bottom.



HOLE PICTURE

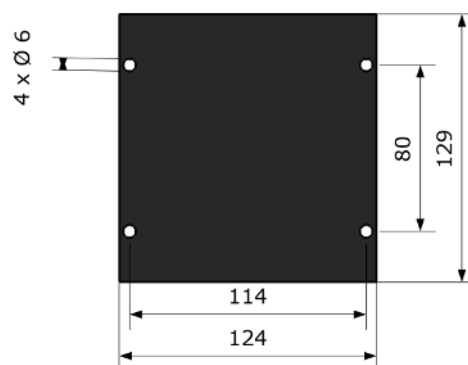
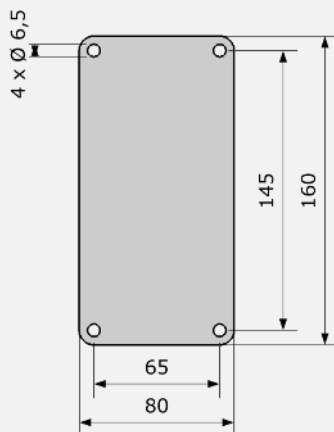

Binar Solutions AB

Box 2001 • SE-461 11 TROLLHÄTTAN • Sweden
 tel +46 (0)520 47 32 00 • fax +46 (0)520 47 32 10
 e-post info@binar.se • webb www.binarsolutions.com



BINAR
 Improving your productivity